



# SUS2023

30.01.19 Therese Øvernes / Johannes Eggen



SUS →  
2023

# SUS2023 PÅ ULLANDHAUG

## - Byggetrinn 1

Kostnadsramme: ca. 8,4 mrd\*



Innflytting i 2023

ca. 100.000 m<sup>2</sup> (på Ullandhaug)

m<sup>2</sup>



Alle somatiske sengepasienter og akuttpasienter samt nødvendige støttefunksjoner flyttes

Byggestart våren 2019



Enerom med bad til alle (ca 640 sengerom er planlagt)

Sandnes  
brannstasjon



Sandnes  
rådhus



Summen av disse er ca.  
100.000 m<sup>2</sup>  
= SUS2023 (BT1)

Konserthuset



SR-bank, finansparken



Eiganes skole

Arkivenes hus



Forum  
Expo



Lervig  
sykehjem



# Områderegulering mars 2017





## Rekkefølgetiltak

Før delområdene KT10, SH og OPT kan tas i bruk, skal følgende være gjennomført:

1. Løsning for overvannshåndtering i friområdet ved Madlaveien
2. Kollektivfelt fra Kjell Arholms gate 41 og frem til Jåttåvågen
3. Egen trase for syklist langs kollektivfeltet som kobles til planlagt sykkelstamvei, i nord via Torg29 og i sør ved Madlaveien.
4. Gangareal/torg langs med kollektivfeltet fra Professor Olav Hanssens vei og til og med Madlaveien
5. Parkeringshus som dekker byggetrinnets behov
6. Ny adkomstvei med nytt kryss med Kristine Bonnevis vei i Sola kommune, med svingefelt dimensjonert for utbyggingen
7. Undergang under Kristine Bonnevis vei ved Madlaveien i Sola kommune

# Utfordring fra HOD

- Sykehusene som bygges er for dyre
- Ønsker at prosjektene tenker nytt
- Størst mulig grad av industrialisering
- Større grad av digitalisering



# Vårt svar

- Standardisering og fleksibilitet
- Mest mulig bygging off-site og montering on-site.
- LEAN gjennomføring
- Heldigitalisert prosjekt (BIM++)





# Vårt svar

1. Gode bygg og områder stimulerer til kontakt, aktivitet og opplevelser	9
2. Gode bygg og områder gir gode lysforhold og utsyn	20
3. Gode bygg og områder gir god luftkvalitet og lav støybelastning	34
4. Gode bygg og områder ivaretar sikkerhet	46
5. Gode bygg og områder ivaretar god tilgjengelighet til og på stedet	52
6. Gode bygg og områder har lang levetid	60
7. Gode bygg og områder gir smart utnyttelse av arealene	64
8. Gode bygg og områder utnytter energien godt	70
9. Gode bygg og områder er bygget med god ressursutnyttelse og lave klimagassutslipp	78
10. Gode bygg og områder gir lave drifts- og vedlikeholdskostnader	84



VALAND  
001





# SITUASJONSPLAN

## Bygg A

- Foyer
- Auditorium/Kirkerom
- Exitlounge
- Apotek (utleie)
- Ventesoner

## Bygg B

- Foyer
- Venteområder

## Bygg CD

- Foyer
- Kantine
- Bibliotek
- Utleie(Kafe)



# Vridde gårdsrom

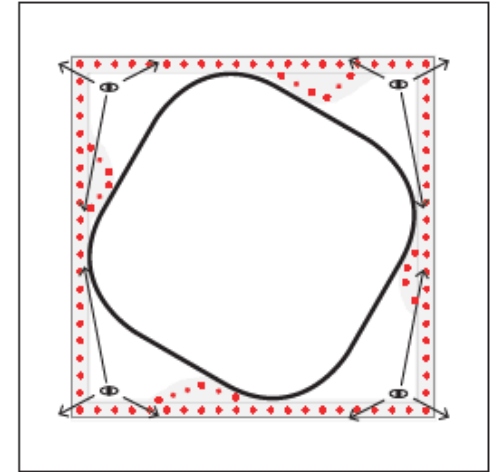
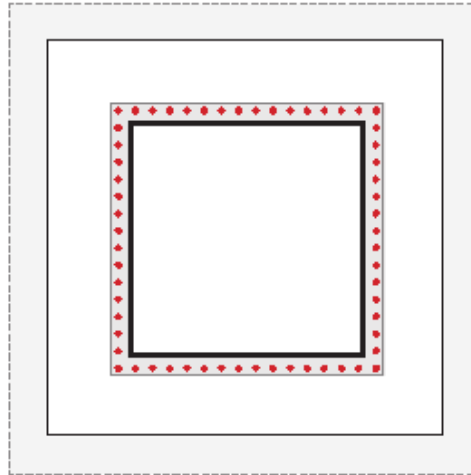
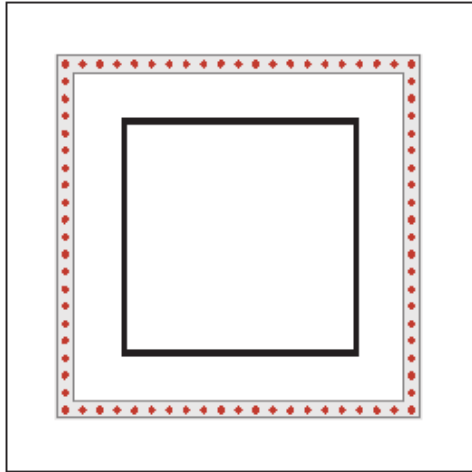

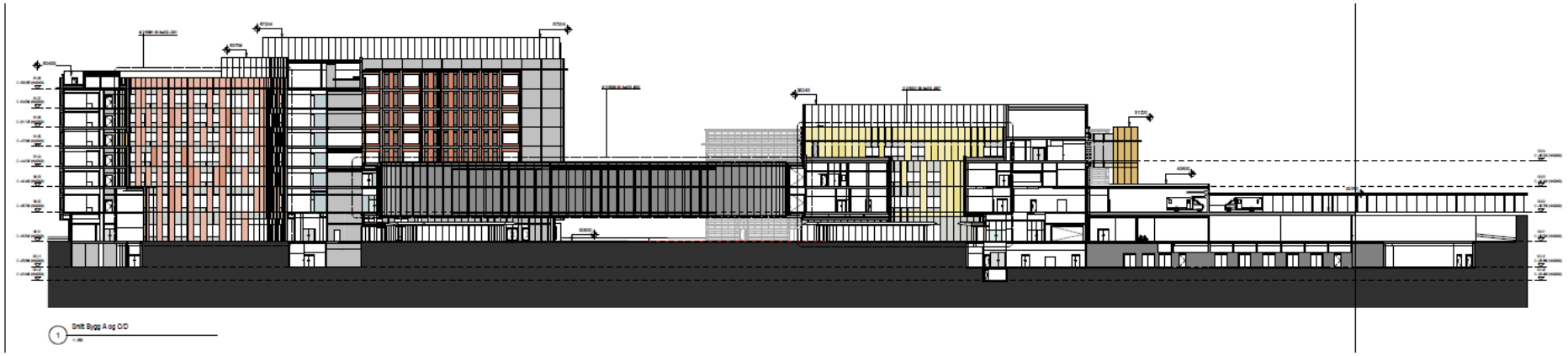

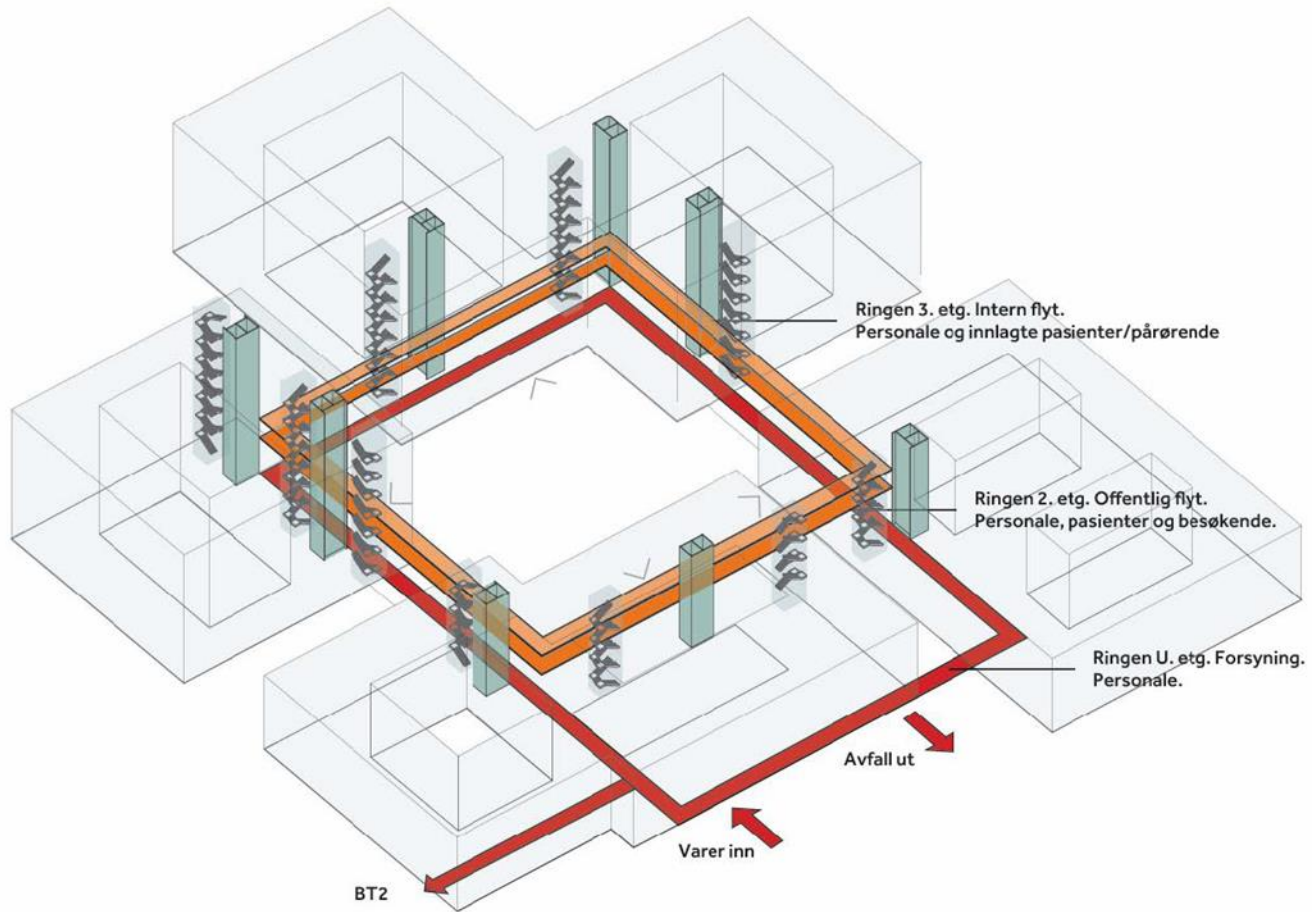



Trapp

Heis / Vareautomat

Sengeautomat

Sengevask

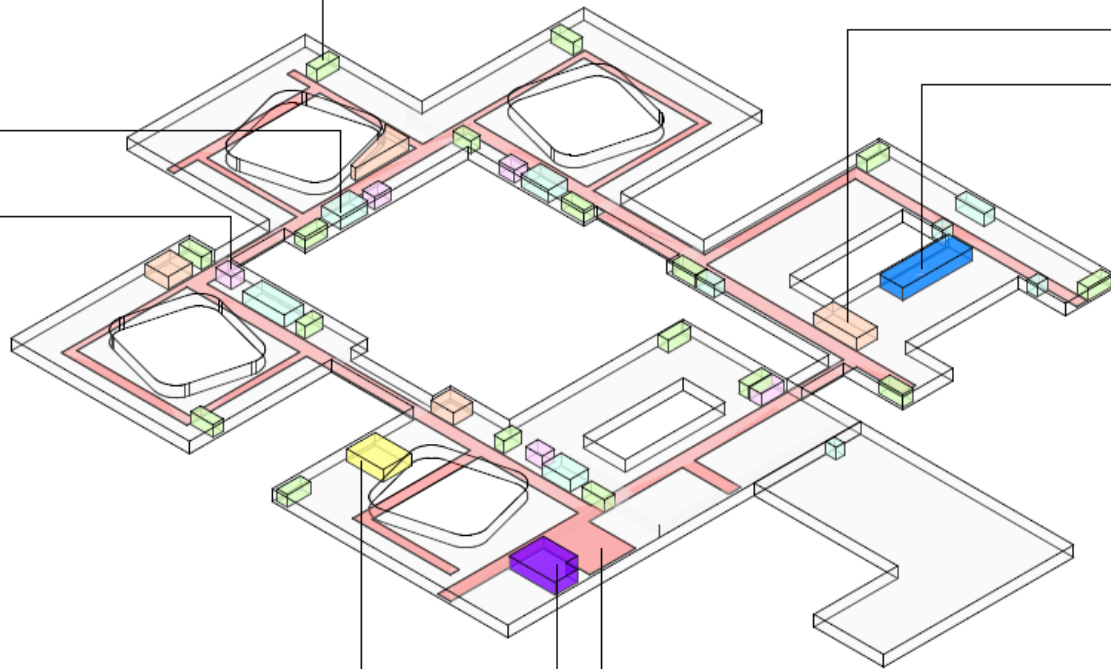

Rørpost

Lager sterilt

Varemotakk

Felles prøve-motakk

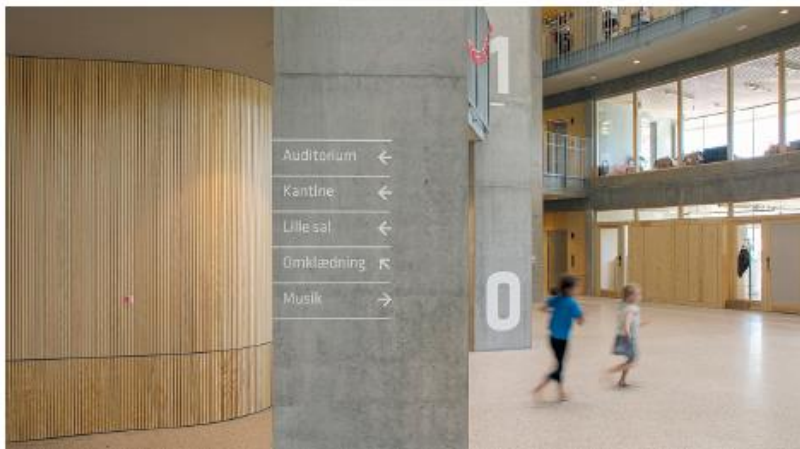

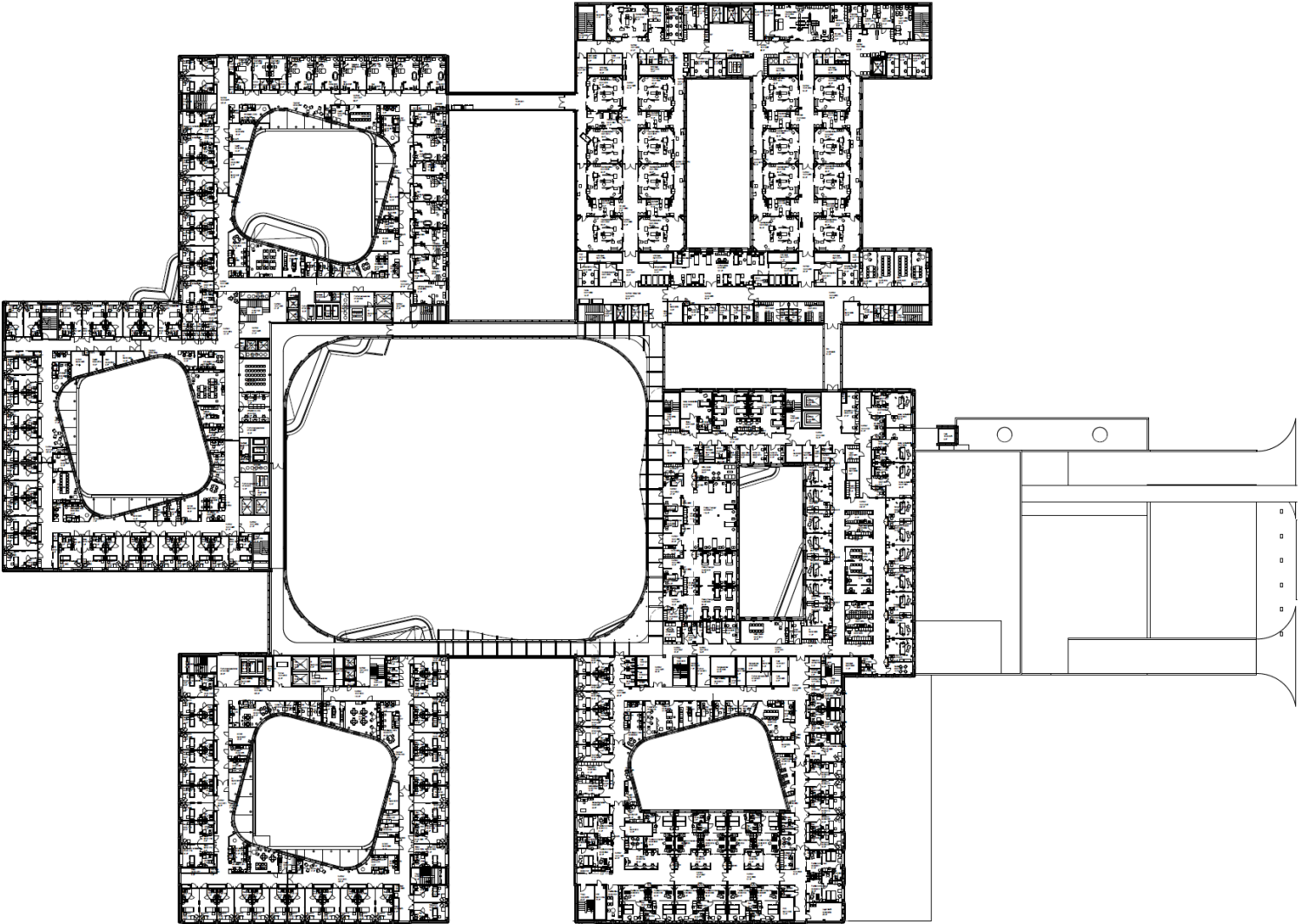



South West Block  
Typical Corner  
Exploded View

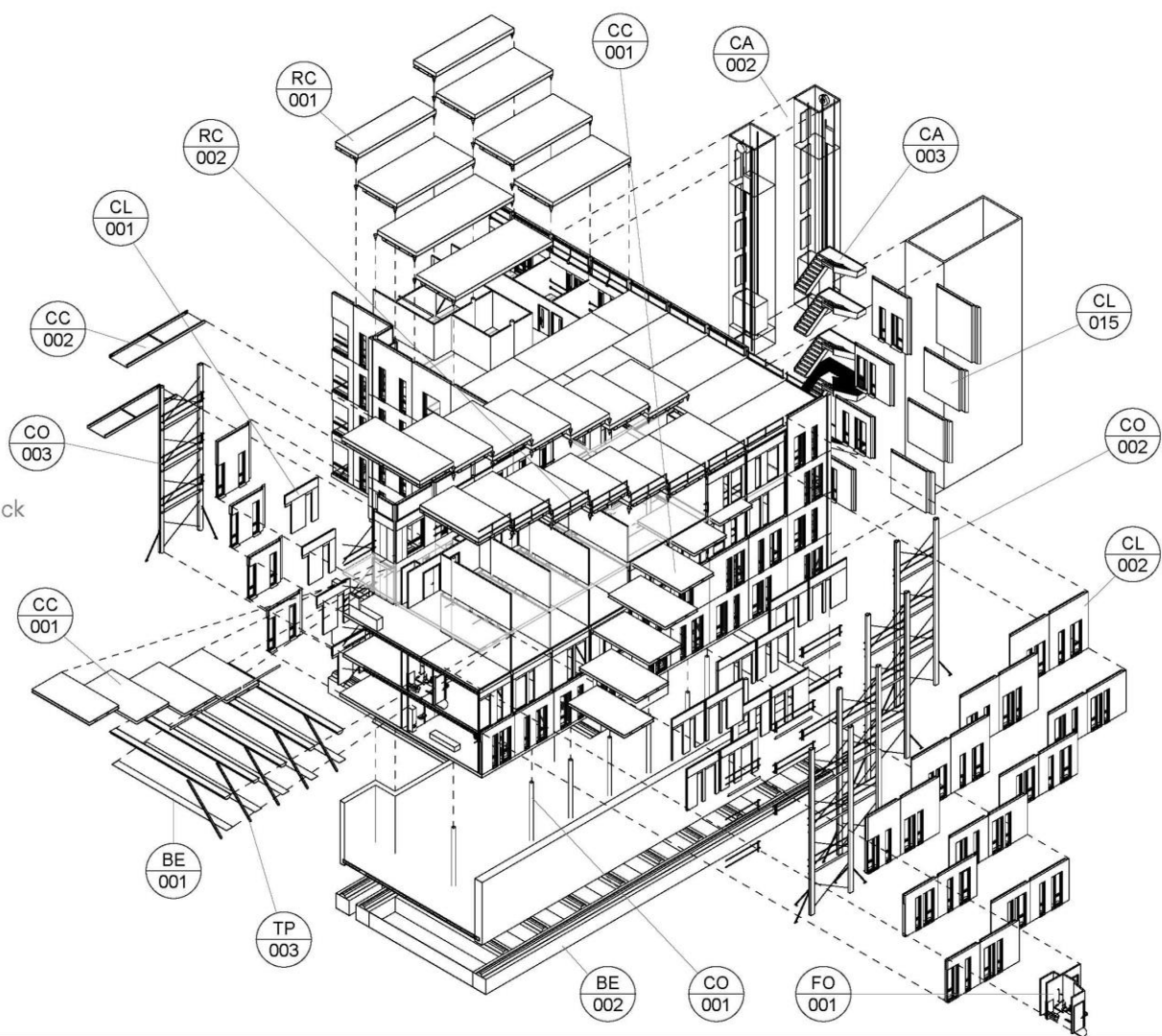



# PREFAB | SENGEROM

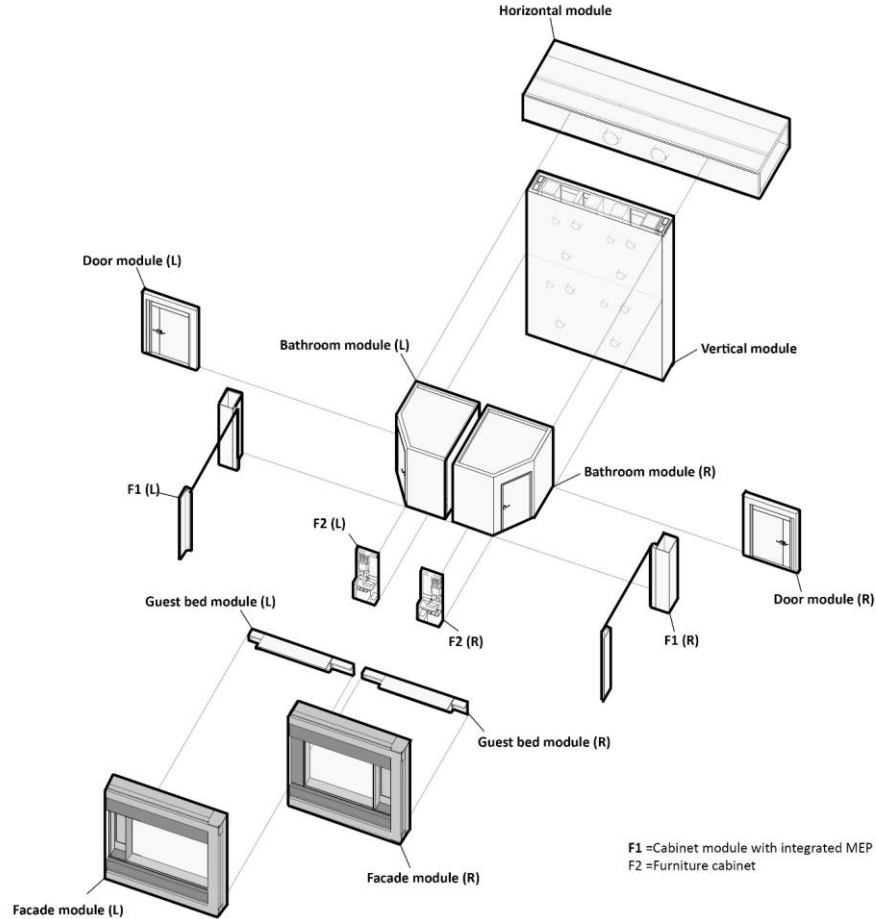

# INNSTØPTE OPPHENGSSKINNER





# FERDIGE HULLTAKINGER I DEKKE



# SERVANTMODULER

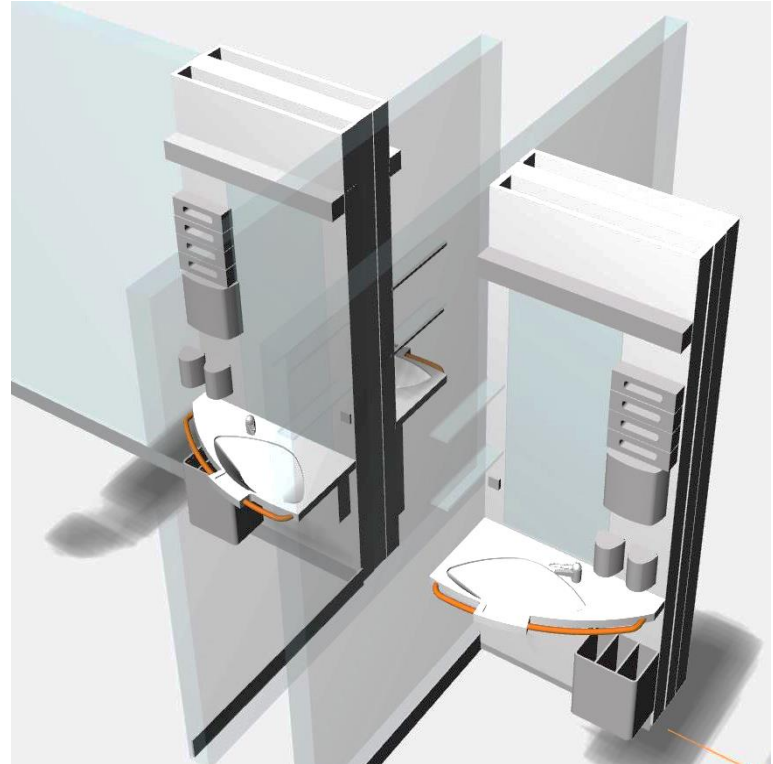
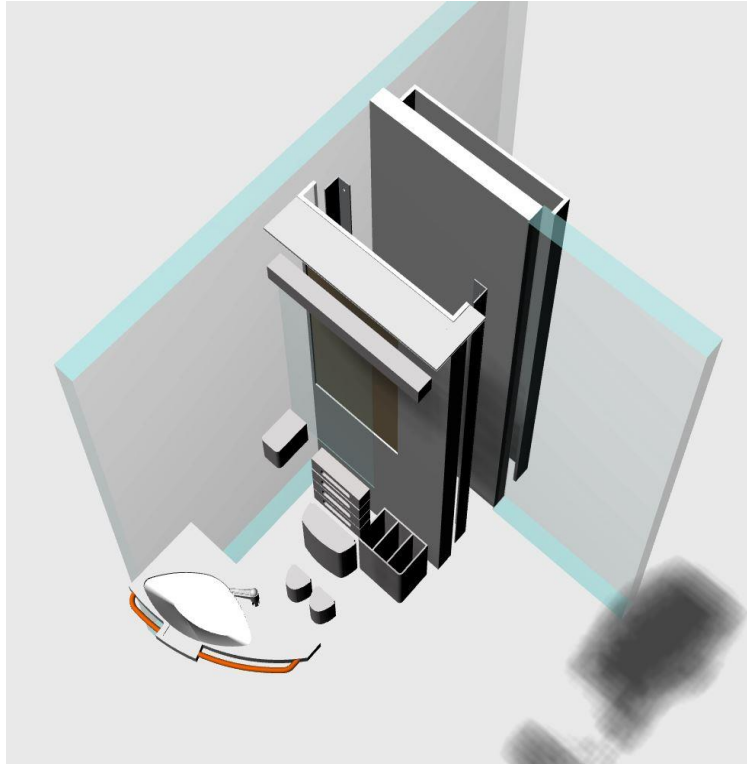

# GJESTESENGER – INNVENDIG FASADE

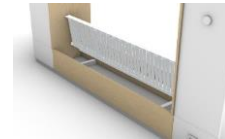
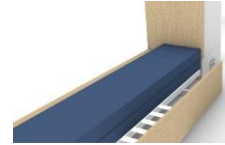

# INNREDNINGER

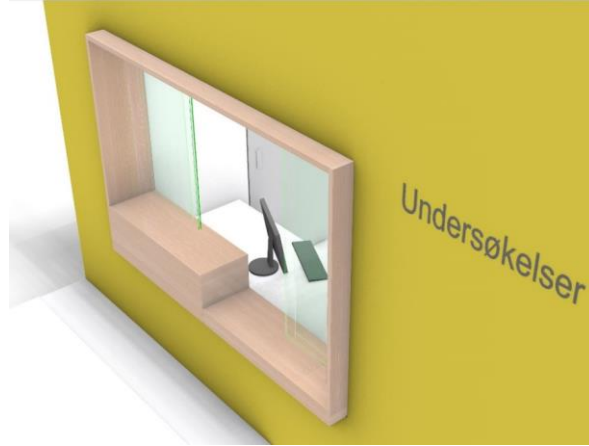





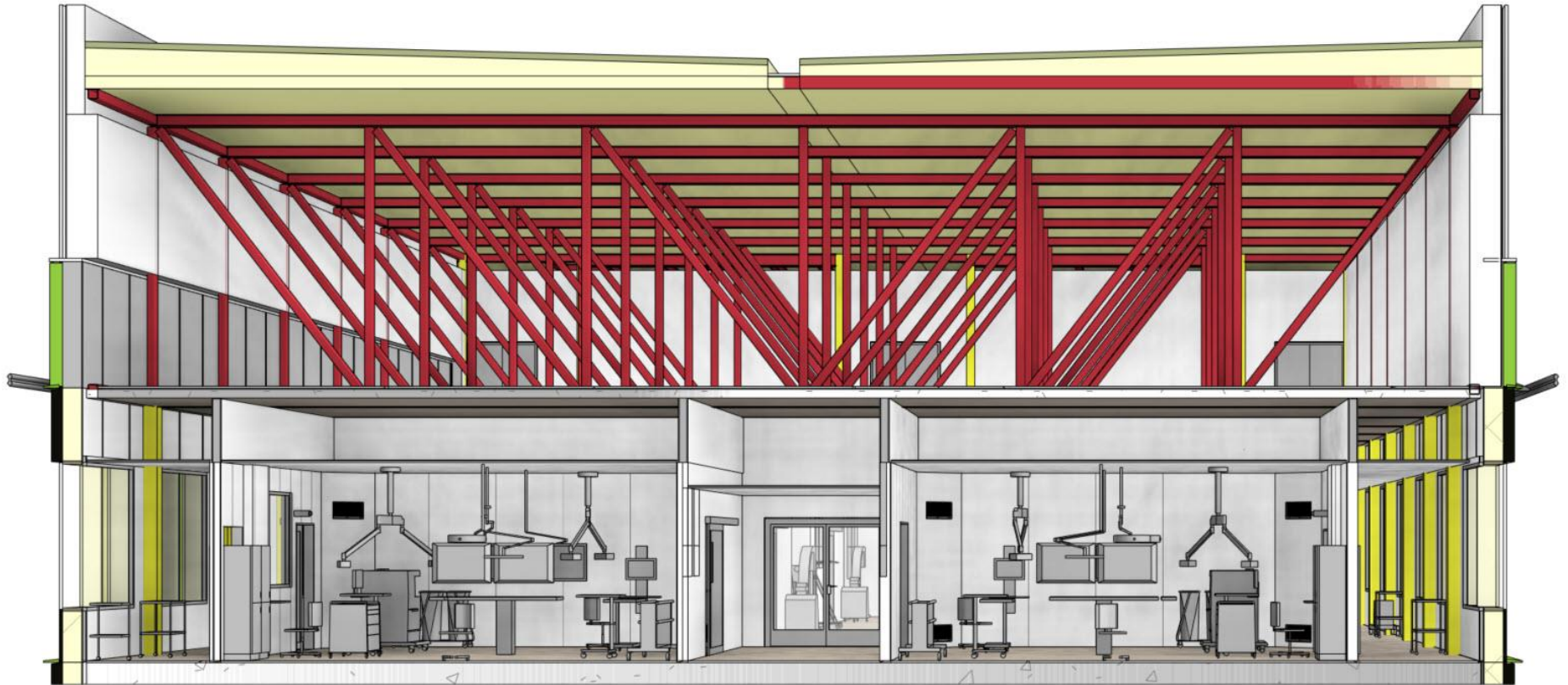

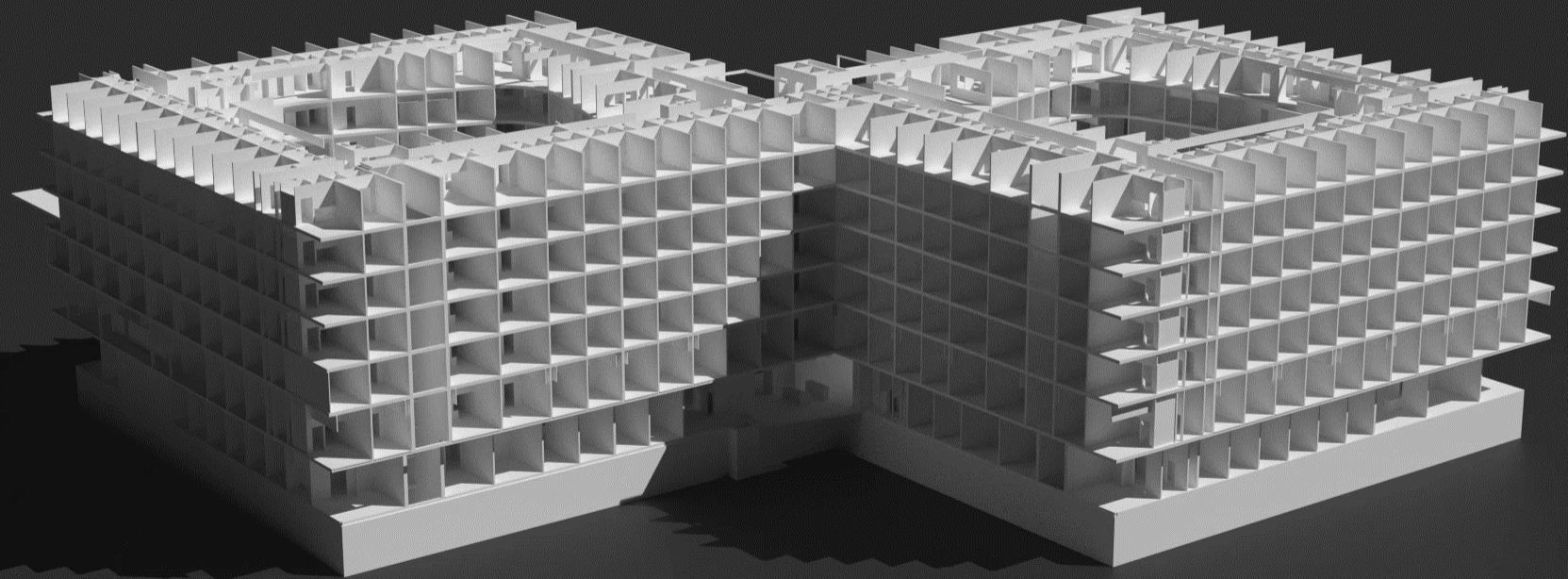







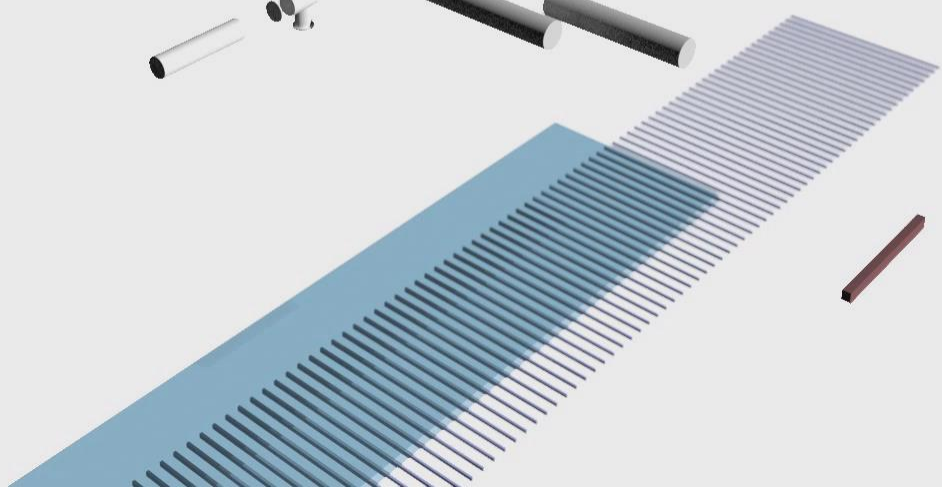
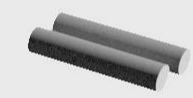
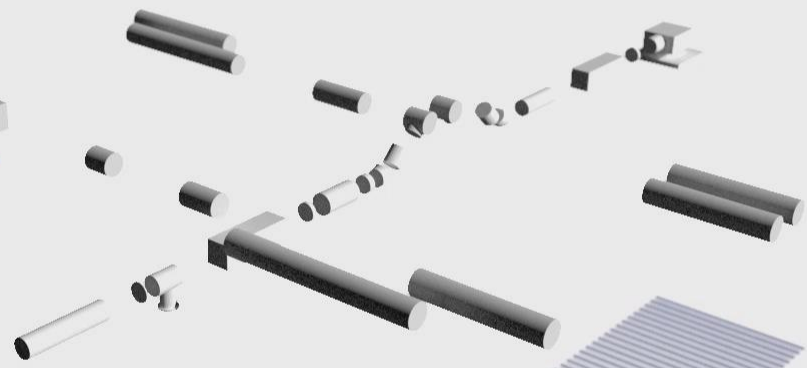
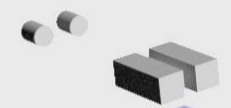
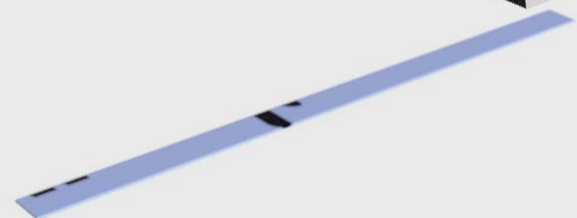

# Norsk milliardprosjekt i Stavanger er verdens beste

Redaksjonen - Hegnar.no for 16 timer siden



© Leveres av ABC Startsiden A/S Stavanger Universitetssykehus (SUS2023) ble kåret til verdens beste digitale byggeprosjekt.

I arbeidet med Stavanger Universitetssykehus (SUS2023) har COWI og Nordics prosjekteringsgruppe knekt koden en hel byggenæring har jaktet på. Tirsdag kveld ble prosjektet kåret til verdens beste digitale byggeprosjekt.

En liten delegasjon av teammedlemmer fra COWI og Nordic – office of Architecture fikk tirsdag overlevert den gledelige nyheten: prosjektet deres er verdens beste digitale byggeprosjekt. Stavanger Universitetssykehus konkurrerte i finaleheatet mot det kinesiske

< 1 2 3 4 >

## MER FRA MSN



SISTE: Her kan det bli 20 grader  
Nettavisen



Dette skjedde i natt  
Photos



En person alvorlig skadet etter kollisjon  
Nettavisen



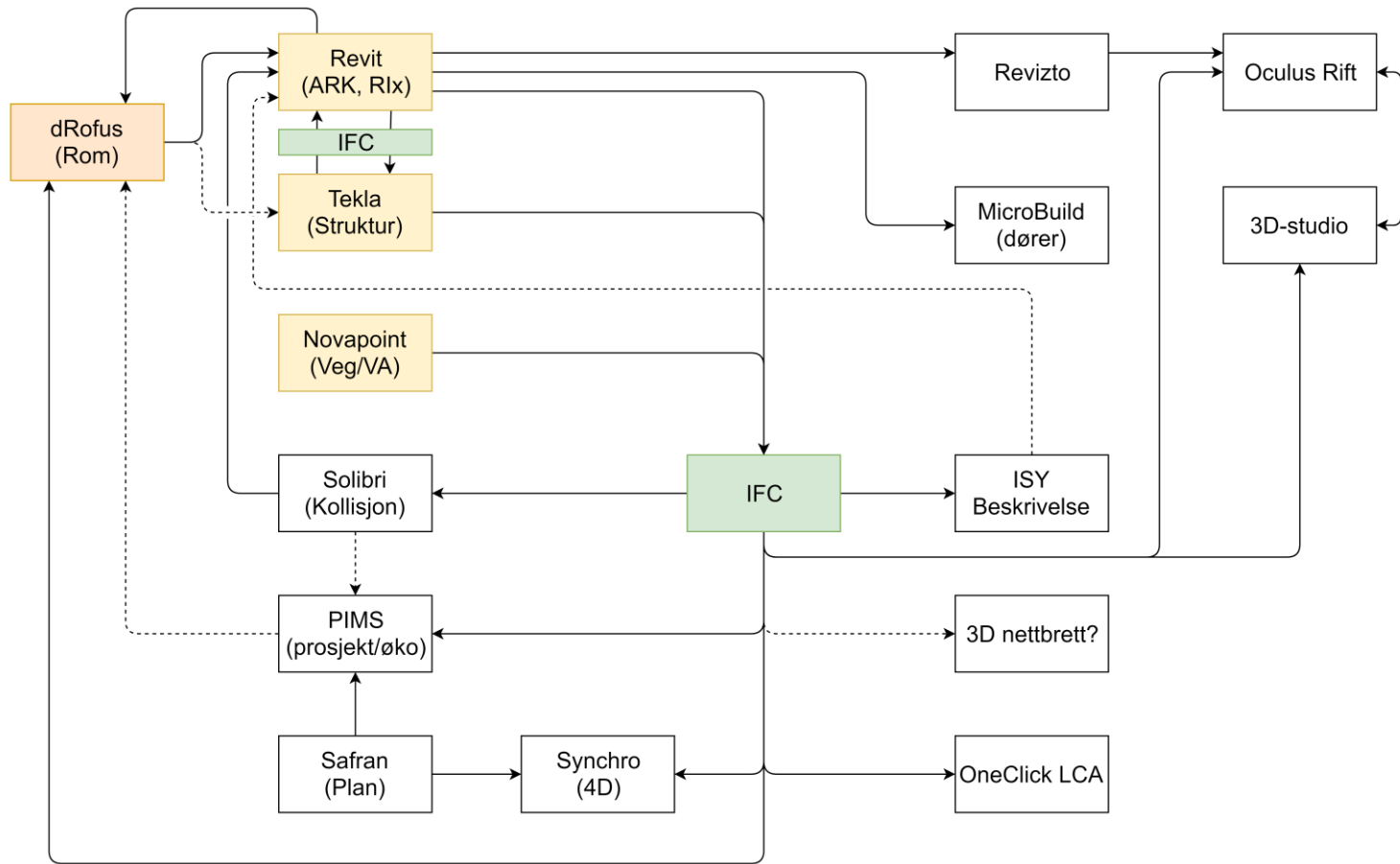

# Takt planlegging

## Takt Planning



## Elements of Takt Planning

### TOG

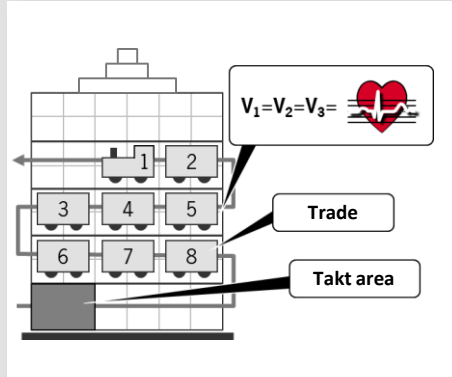

Rekkefølgen på arbeidet

### TAKT OMRÅDER

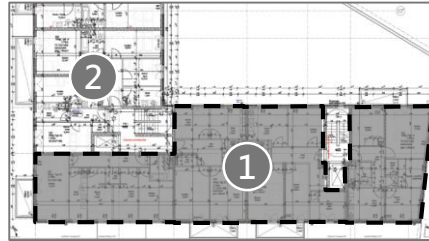

- Arbeidet for en takt her: en uke
- Antall resurser optimalisere

### TAKT PLAN

- Like tog for like områder

# Takt kontroll

## Takt Control





# TAVLE MØTE

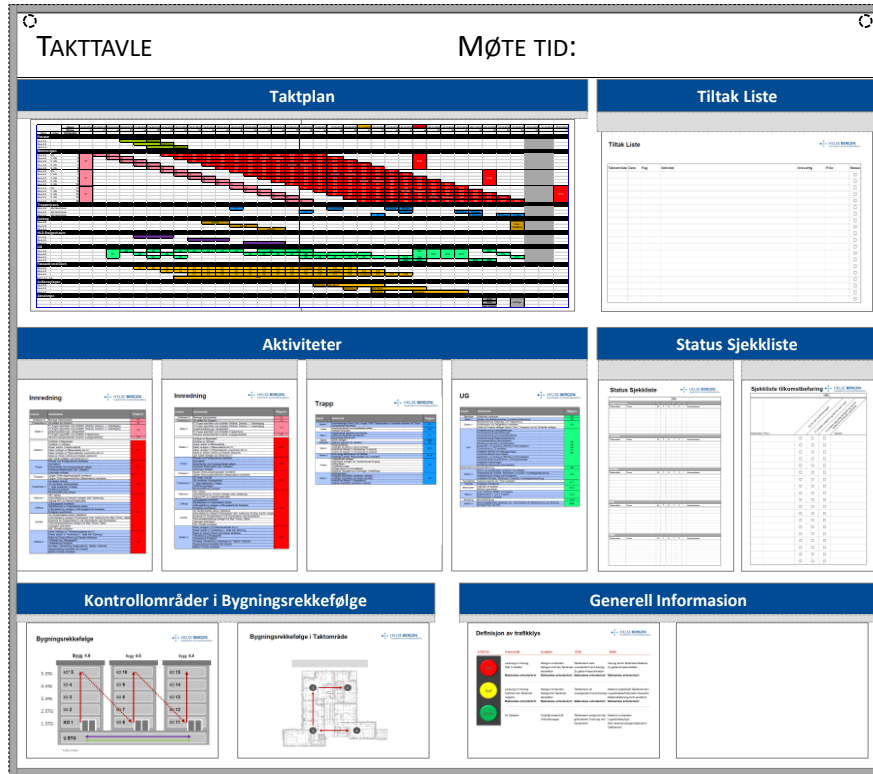



# Laserscanning

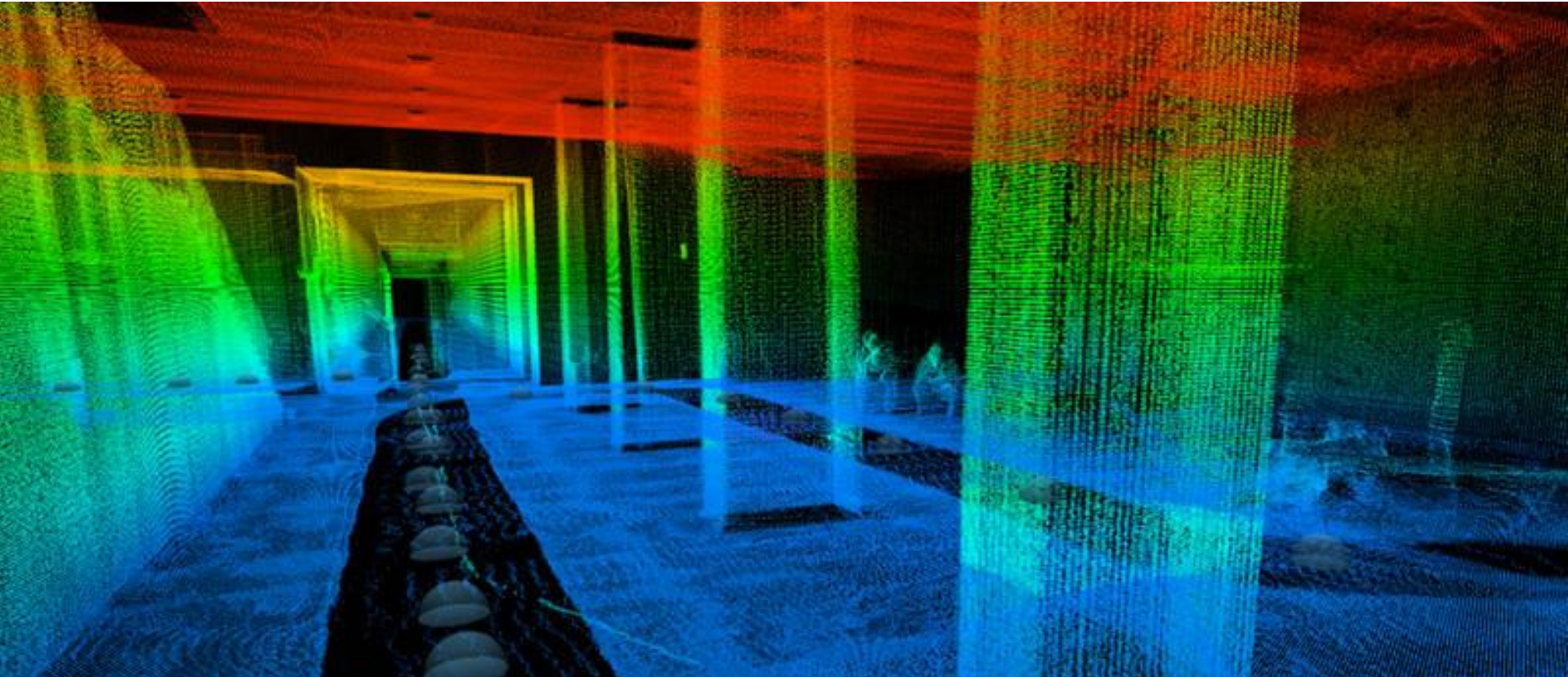

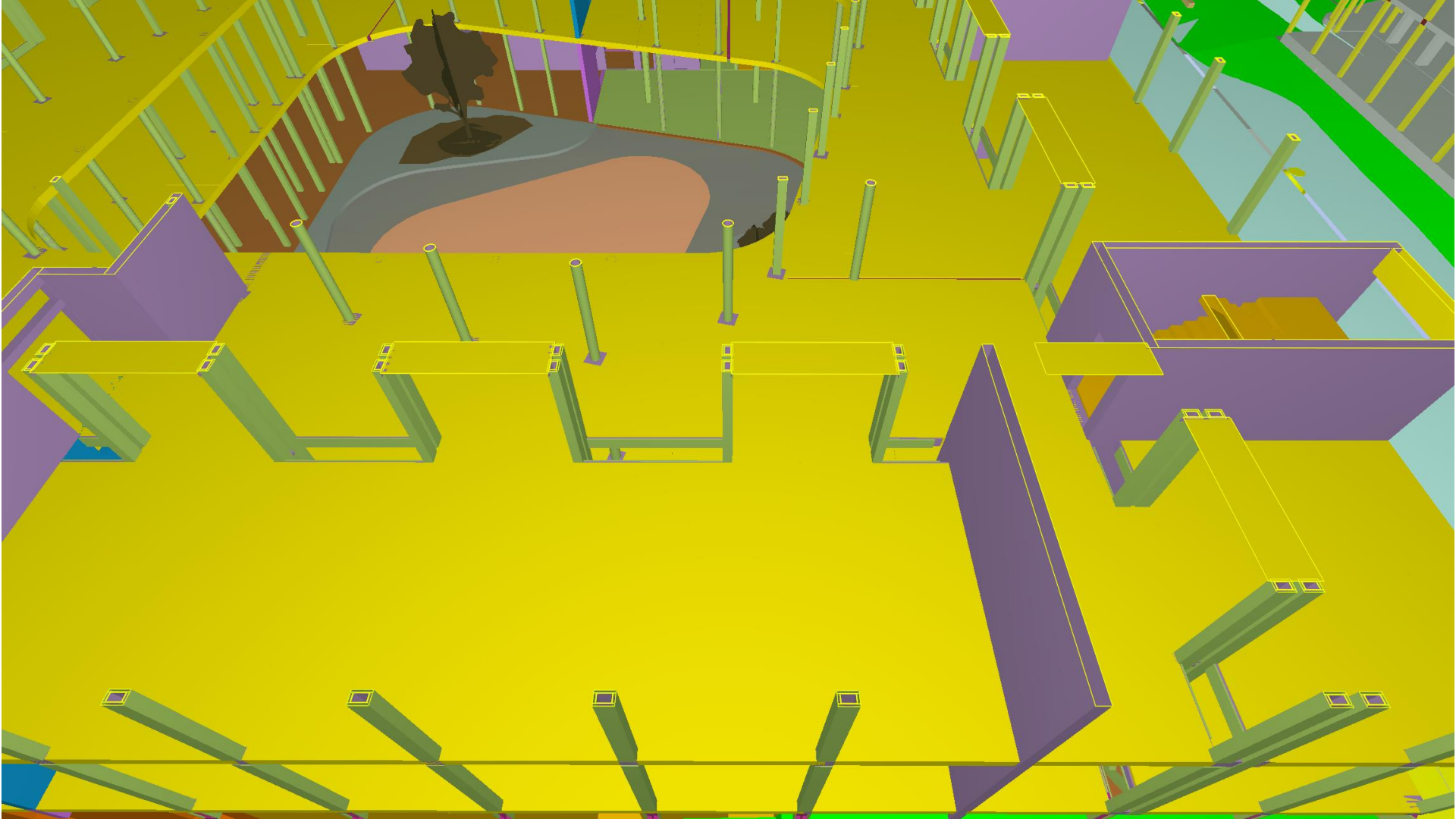

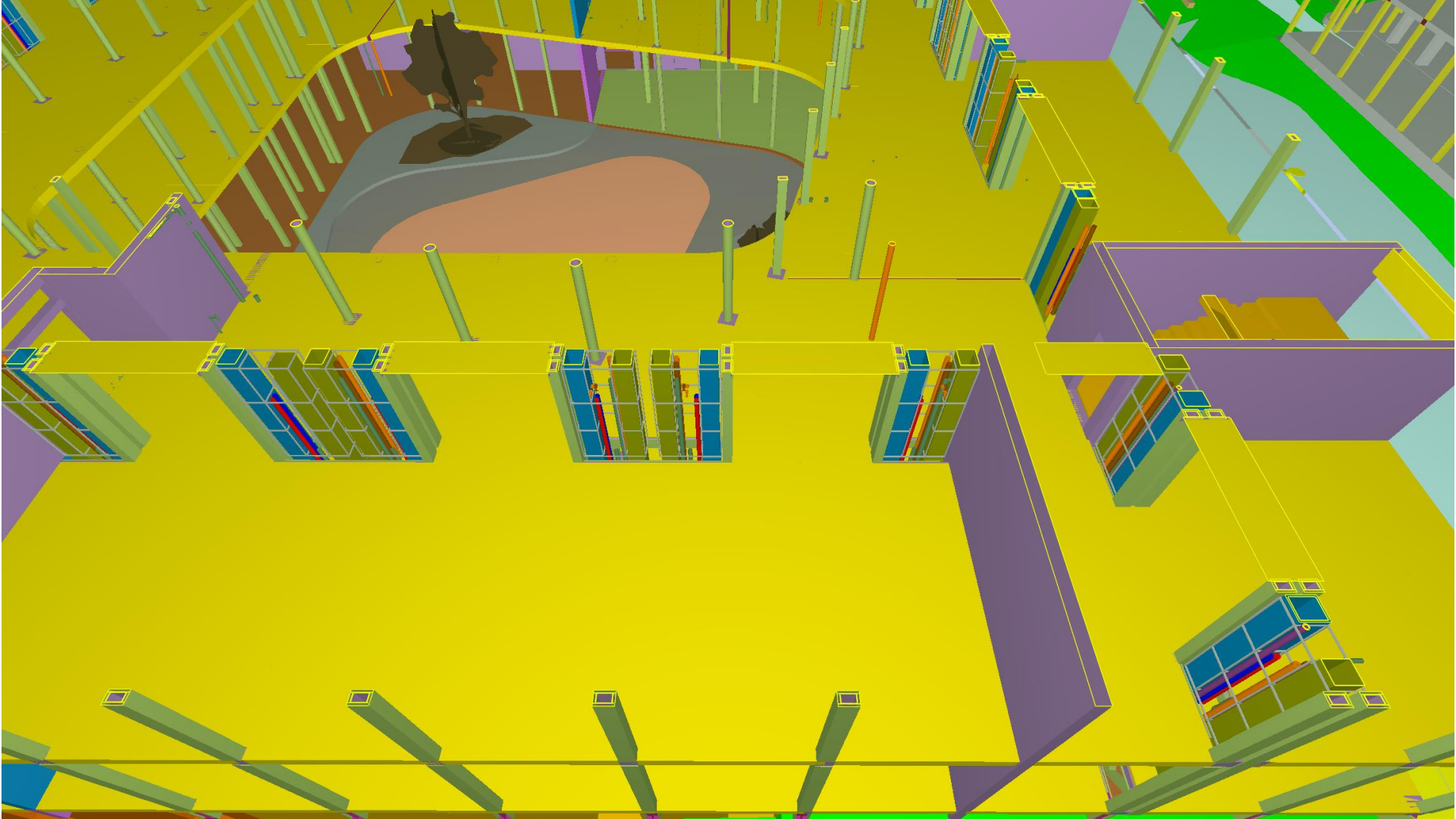

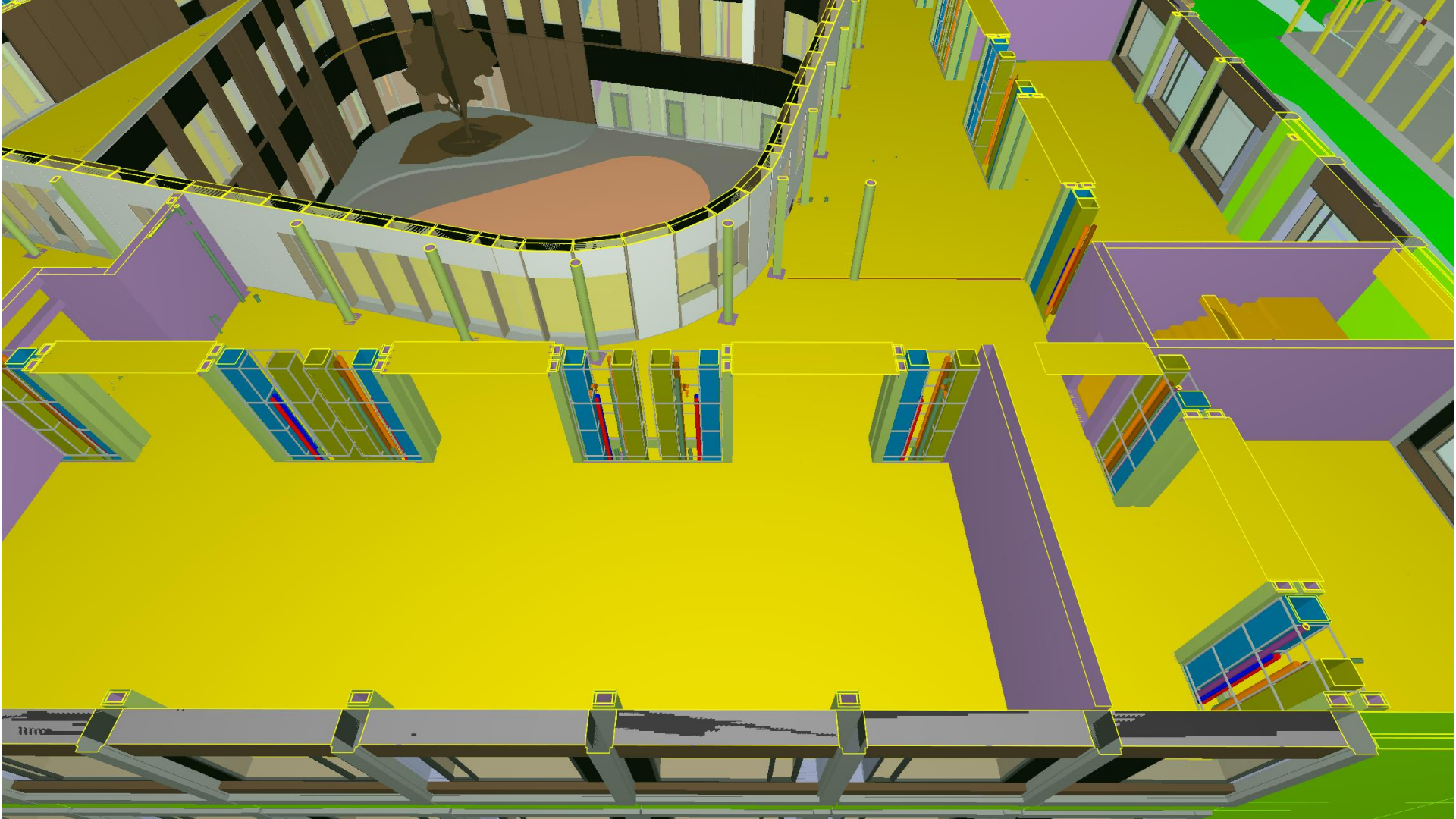

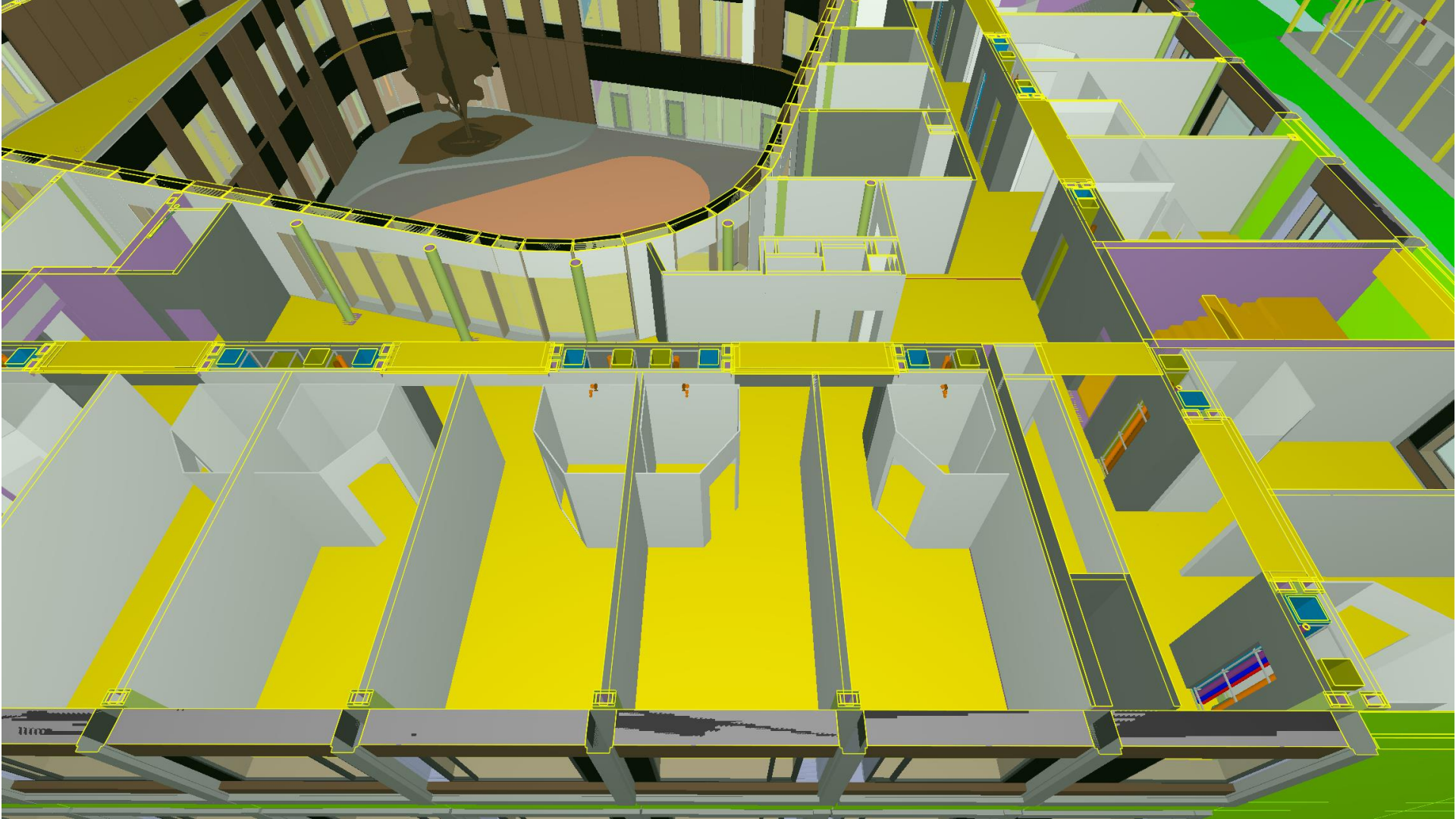

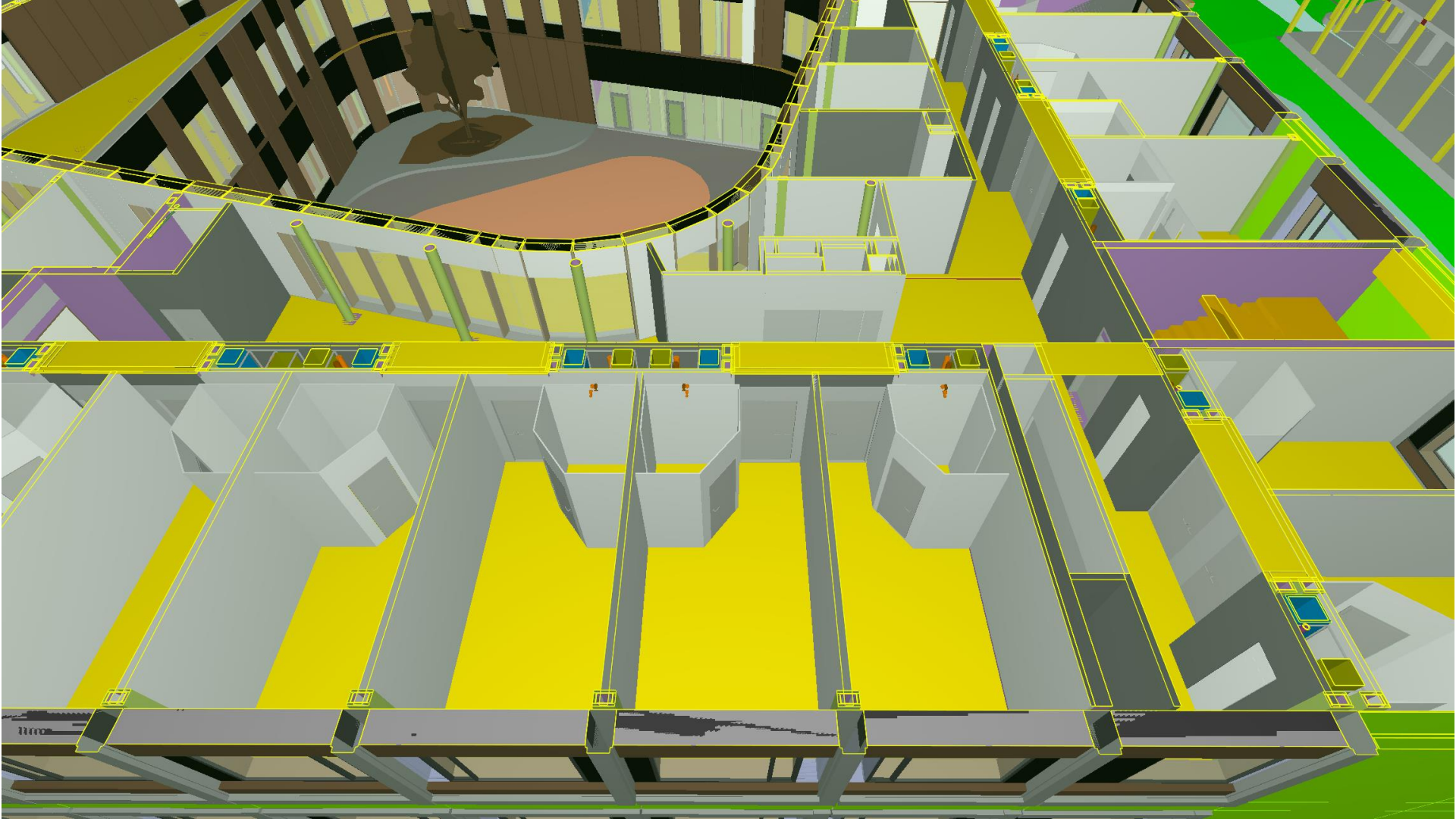



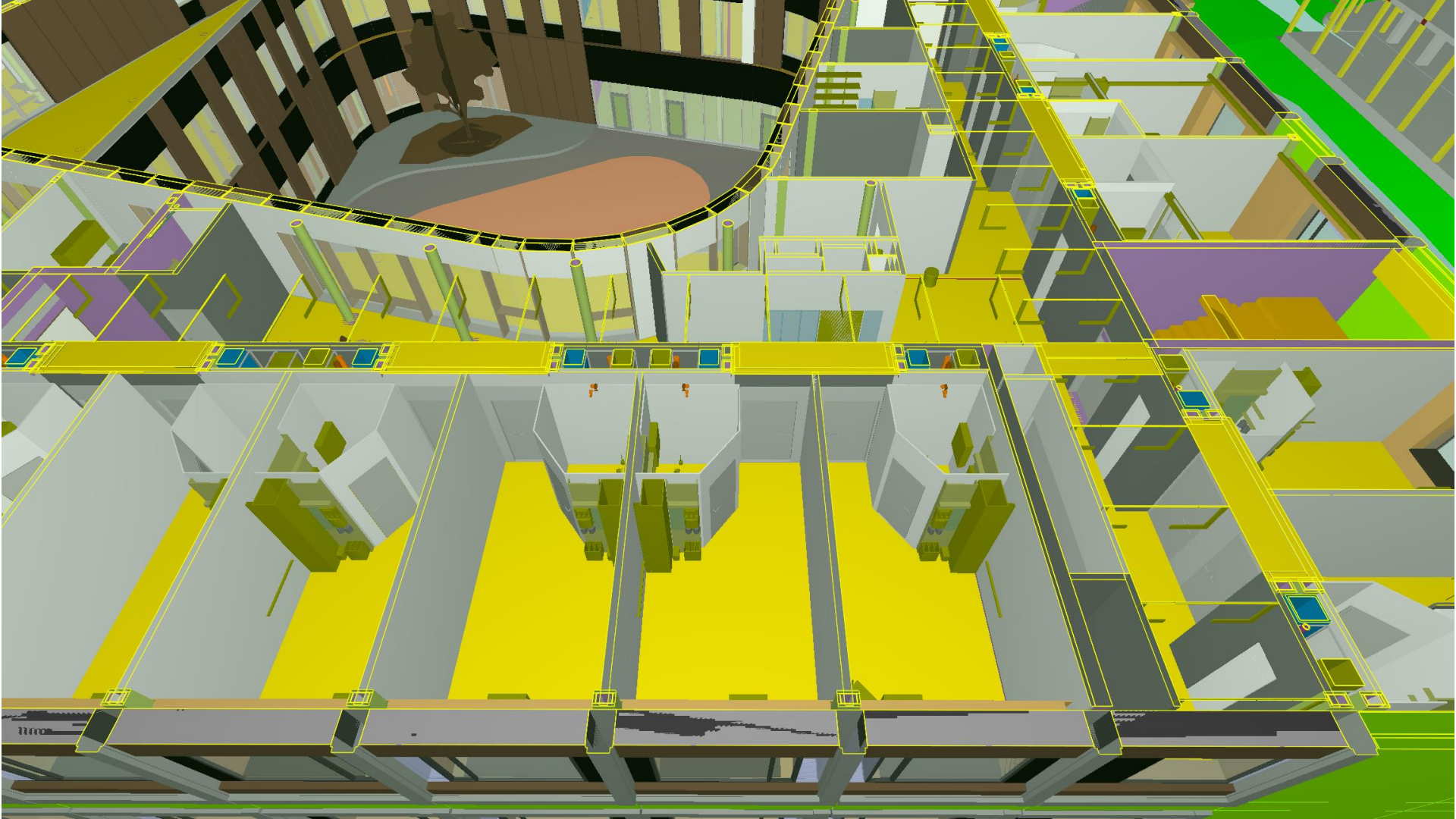

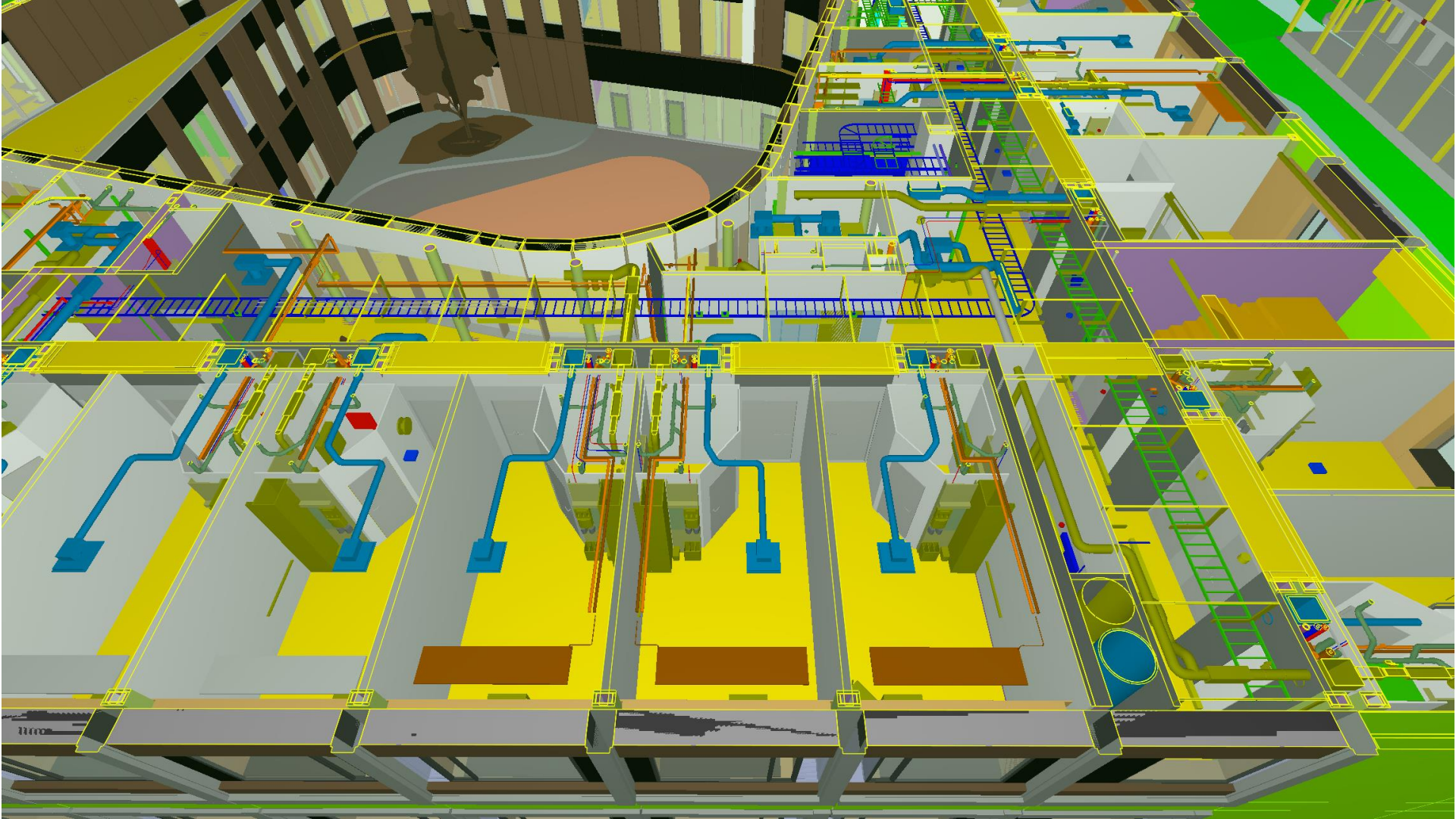

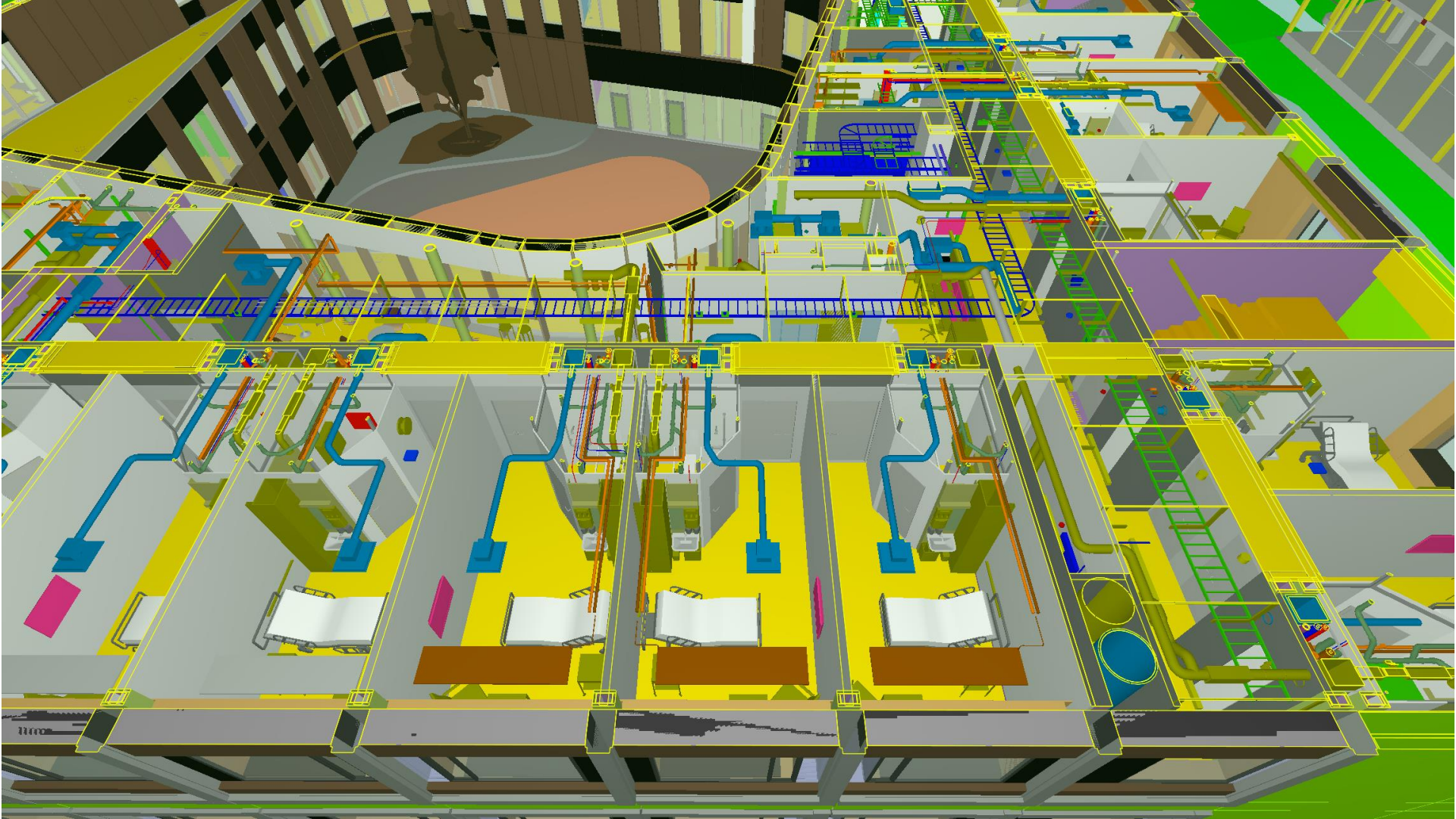



# Takk for oppmerksomheten

## [www.sus.no](http://www.sus.no)



@stavanger.universitetssjukehus



@stavangeruniversitetssjukehus



@stavangeruniversitetssjukehus